

SIMFLO

ENCLOSED LINESHAFT

— VERTICAL TURBINE PUMP —

Our Enclosed Lineshaft Vertical Turbine Pump, featuring a best-in-industry design, is ideal for municipal, industrial, and agricultural applications that require consistent flow rates and unmatched durability.

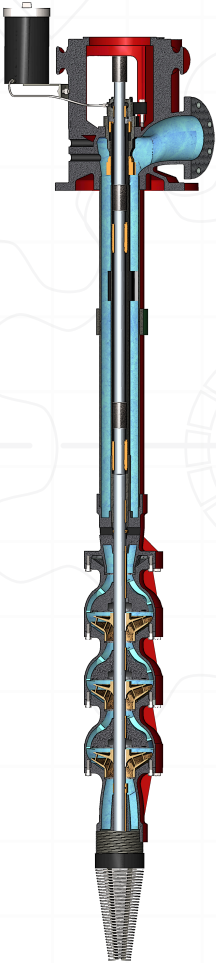

- BOWL MODELS RANGING FROM 4" - 28" WITH FLOWS FROM 50 - 18,000 GPM
- C955 NICKEL ALUMINUM BRONZE IMPELLERS AS WELL AS 316 STAINLESS STEEL IMPELLERS AVAILABLE
- BOWL CASTINGS FEATURE THICKER WALLS FOR HIGHER PRESSURE RATINGS AND LONGER WEAR LIFE
- CLASS 30 AND DUCTILE IRON CAST DISCHARGE HEADS ARE STOCKED FOR IMMEDIATE SHIPMENT
- FABRICATED DISCHARGE HEADS ARE DESIGNED AND CUSTOM BUILT PER YOUR SPECIFICATION
- AVAILABLE WITH PACKING GLAND OR MECHANICAL SEAL ARRANGEMENTS
- COMPONENTS ARE AVAILABLE IN A WIDE VARIETY OF MATERIALS TO SUIT THE NEEDS OF YOUR UNIQUE APPLICATION
- PRESSURIZED OR RECIRCULATING FLUSH AVAILABLE WITH PACKING GLAND OR MECHANICAL SEAL ARRANGEMENT

SIMFLO

SIMFLO

OPEN LINESHAFT

VERTICAL TURBINE PUMP

Our Open Lineshaft Vertical Turbine Pump is engineered to meet a wide variety of applications. Featuring custom materials and configurations, our products are manufactured and tested in adherence with our quality management system, ensuring you will receive the best product in the industry.

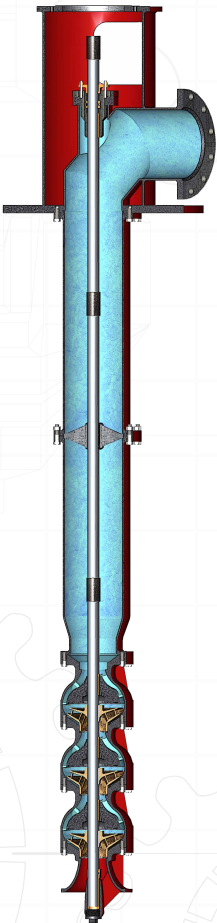

- AVAILABLE IN SIZES 4" - 28" WITH FLOWS FROM 50 - 18,000 GPM
- C955 NICKEL ALUMINUM BRONZE IMPELLERS AS WELL AS 316 STAINLESS STEEL IMPELLERS AVAILABLE
- BOWL CASTINGS FEATURE THICKER WALLS FOR HIGHER PRESSURE RATINGS AND LONGER WEAR LIFE
- CLASS 30 AND DUCTILE IRON CAST DISCHARGE HEADS ARE STOCKED FOR IMMEDIATE SHIPMENT
- FABRICATED DISCHARGE HEADS ARE DESIGNED AND CUSTOM BUILT PER YOUR SPECIFICATION
- AVAILABLE WITH PACKING GLAND OR MECHANICAL SEAL ARRANGEMENTS
- COMPONENTS ARE AVAILABLE IN A WIDE VARIETY OF MATERIALS TO SUIT THE NEEDS OF YOUR UNIQUE APPLICATION



SIMFLO

SUBMERSIBLE

PUMP

Durability meets versatility when it comes to our submersible pump. **SIMFLO'S** dedication to using robust, cast bowl and impeller components sets our product apart from the competition. This configuration can handle high head requirements, vertical to horizontal installations and is the perfect choice when operating under surface noise restrictions.

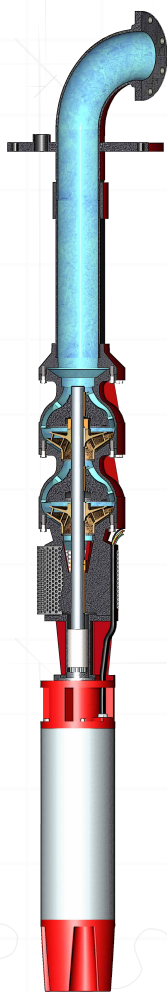

- BOWL MODELS RANGING FROM 4" - 28" WITH FLOWS FROM 50 - 18,000 GPM
- C955 NICKEL ALUMINUM BRONZE IMPELLERS AS WELL AS 316 STAINLESS STEEL IMPELLERS AVAILABLE
- BOWL CASTINGS FEATURE THICKER WALLS FOR HIGHER PRESSURE RATING AND LONGER WEAR LIFE
- FABRICATED DISCHARGE HEADS ARE DESIGNED AND CUSTOM BUILT PER YOUR SPECIFICATION
- COMPONENTS ARE AVAILABLE IN A WIDE ARRAY OF MATERIALS TO SUIT THE NEEDS OF YOUR UNIQUE APPLICATION



SIMFLO

HI/LO SERIES

PUMPS

This proven construction is perfect for a wide variety of installations and is maintained in stock for your well supply needs.

"S"

SERIES



- STAINLESS STEEL CONSTRUCTION
- STAINLESS STEEL DISCHARGE WITH BUILT-IN CHECK VALVE
- HIGH-EFFICIENCY STAINLESS STEEL IMPELLERS AND DIFFUSERS
- STAINLESS STEEL SUCTION SCREEN
- STAINLESS STEEL SHAFT AND COUPLING
- STAINLESS STEEL NEMA FACED MOUNTING BRACKET
- AVAILABLE IN 4", 6", 8", AND 10" DIAMETERS
- CAPACITIES AVAILABLE FROM 5 GPM TO 1200 GPM

"N"

SERIES



- STAINLESS STEEL DISCHARGE WITH BUILT-IN CHECK VALVE
- STAINLESS STEEL MOTOR ADAPTER, CASING, STRAINER AND PUMP SHAFT TO INCREASE DURABILITY
- NORYL IMPELLERS TO INCREASE LIFE IN ABRASIVE CONDITIONS
- DURABLE URETHANE BEARINGS
- AVAILABLE IN 4" DIAMETER
- CAPACITIES AVAILABLE FROM 5 GPM TO 80 GPM

SIMFLO PUMP CONFIGURATIONS

SIMFLO offers a wide variety of pump configurations, alternate materials, and coating options in order to produce the best possible product to keep your business flowing.

HERE ARE SOME OF OUR MOST POPULAR CONFIGURATIONS:

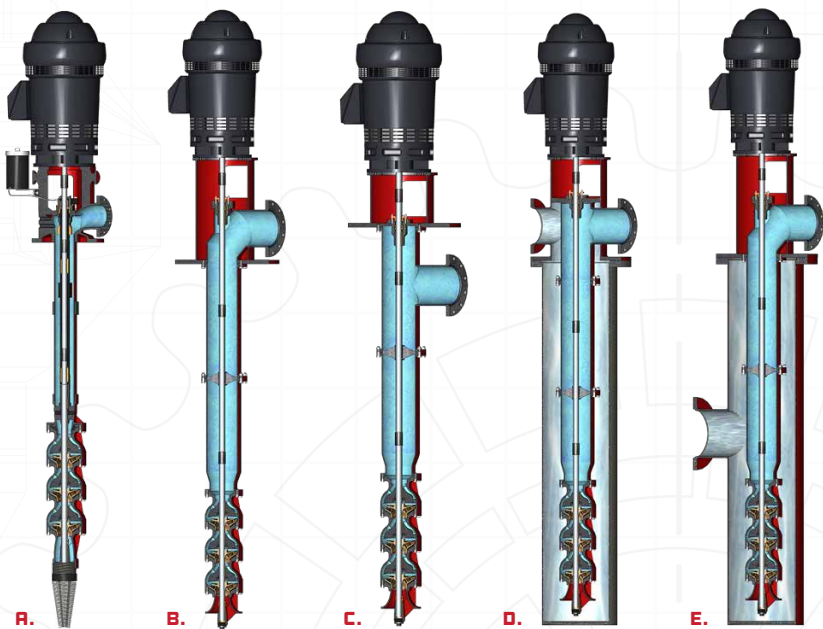

- A.** DEEP WELL PUMP WITH CAST IRON DISCHARGE HEAD
- B.** SHORT COUPLED PUMP WITH FABRICATED STEEL "L" DISCHARGE HEAD
- C.** SHORT COUPLED PUMP WITH FABRICATED STEEL MOTOR STAND AND UNDERGROUND DISCHARGE
- D.** SHORT COUPLED PUMP IN CAN WITH FABRICATED STEEL "T" DISCHARGE HEAD
- E.** SHORT COUPLED PUMP IN CAN WITH FABRICATED STEEL "L" DISCHARGE HEAD